



AmericanAirFilter®

SAAF™ PORTA-Scrubber

Multipurpose, Industrial Grade Portable Scrubber

Better Air is Our Business®



SAAF™ PORTA-Scrubber

Multipurpose, Industrial Grade PORTABLE Scrubber

- Units available as Powered and Non-Powered
- Ideal for a wide variety of applications
- Suitable for outdoor installation
- Compact design is space efficient while reducing capital and installation costs
- Quick, easy installation and operation in a self-contained system — virtually maintenance free
- Corrosion resistant, cast aluminum fan with a single-phase motor on Powered units
- Designed to remove gaseous and particulate contaminants from the airstream in the most demanding applications
- Ultra-high capacity SAAFCarb™ MA.HT chemical media provides complete contaminant removal and longer service life than conventional scrubber media currently available



SAAF™ PORTA-Scrubber 200



SAAF™ PORTA-Scrubber 200NP

Industrial Strength Scrubbing Power

Contaminated air enters the bottom of the scrubber where the open-air plenum allows the air to evenly distribute across the SAAF™ media bed.

SAAF media neutralizes the gaseous contaminants within the air as the contaminated air is drawn through the media. Once the air has passed through, it is exhausted through the standard cast aluminum, 120V, single-phase fan/motor assembly that is corrosion resistant even in aggressive environments.



High Capacity Solution in a Portable, Economical Unit

The SAAF PORTA-Scrubber is an economical, yet heavy-duty, quick and easy to use and install solution for removal of high concentrations of gaseous contaminants from low volume airflows. This portable scrubber is effective within a wide variety of municipal odor control, industrial, and commercial gas removal applications.

The PORTA-Scrubber can be effectively used in a variety of fugitive emission applications, including sewage pumping station odor control or headworks, laboratory vent hood scrubbing, and at breather exhausts of chemical storage tanks. The PORTA-Scrubber is designed to induce a positive or negative pressure, depending on the application, on any enclosed space or vent.



The SAAF™ PORTA-Scrubber can be used to capture fugitive emissions from laboratory vent hoods or chemical storage tanks.

SAAF™ Airborne Molecular Contaminant (AMC) Chemical Media and Catalysts

AAF offers the largest variety of high efficiency filtration media for effective removal of contaminants known to produce odorous, corrosive, or unpleasant conditions in a wide variety of environments. SAAF Chemical Media are available as SAAF Custom Blends and SAAF Gas Specific Solutions.

The SAAF Technical Services Group performs comprehensive evaluations and environmental assessments, including remaining media life analysis calculations.

SAAF Gas Specific Solutions are designed for targeted gas removal. SAAFCarb MA, manufactured expressly for odorous environments, is ideal for pump stations located near schools or sensitive neighborhoods. SAAFCarb™ MT.HT is the highest capacity hydrogen sulfide removal product on the market. When evaluated in terms of dollars per pound of hydrogen sulfide removed, SAAFCarb™ MA.HT is found to be the most economical media on the market for hydrogen sulfide.

SAAF Custom Blends are proprietary blends designed for specific applications to provide comprehensive environmental air quality solutions.

SAAF PORTA-Scrubber is suitable for removal of corrosive gas in targeted industrial and cleanroom applications.

SAAF Chemical Media are powerful enough for high capacity industrial applications, yet suitable in mission-critical applications.



Applications

The versatility of the PORTA-Scrubber makes it an ideal solution for gas removal applications in:

- Laboratory Exhaust Systems
- Automotive Manufacturing
- WWTP Collection Systems
- Pharmaceutical
- Pulp and Paper
- Oil Refining
- Semiconductor
- Food Processing

AmericanAirFilter®

SAAF™ PORTA-Scrubber

Product Information

Model Type	Nominal Height (in.)	Nominal Diameter (in.)	Inlet Diameter (in.)	Maximum Airflow (CFM)	Nominal Media Capacity (cu. ft.)
PS-200	51	24	4	200	5
PS-200NP	49	24	4	200	5
PS-500	72	39	6	500	17
PS-500NP	65	39	6	500	17

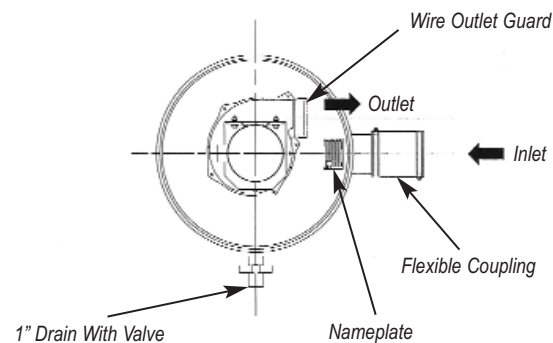
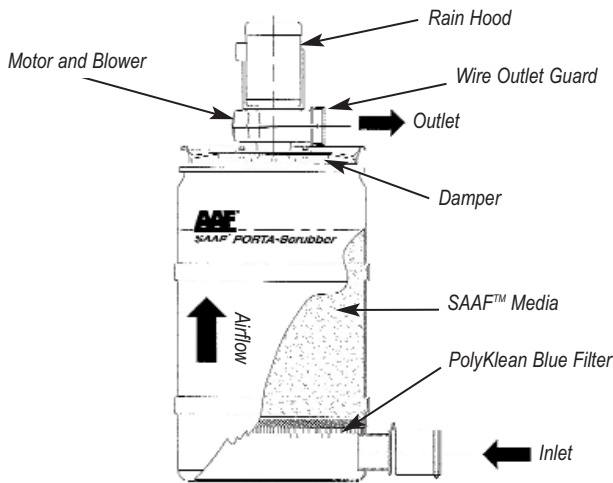

Typical Schematic Arrangement

Engineering Solutions

The Research & Development group is headquartered in Louisville, Kentucky, USA, with staff located in Europe and Asia. Each member of the group is committed to advancing the state-of-the-art in air filtration. R&D's role is to recognize emerging needs and anticipate future air filtration requirements, in order to provide solutions in a timely manner. Their accumulated years of experience, in synergy with a worldwide network of academic and industrial resources, ensure that AAF will always offer excellence in air filtration.

The Product Engineering staff is also located in Louisville, Kentucky, USA, and in key manufacturing facilities around the world. They are a team focused on current markets, with an objective of continuous improvement and services to provide maximum value to our customers. They also quickly adapt our products to meet short-term changes in filtration requirements as they arise in the marketplace.

SAAF™ Technical Services

The SAAF Technical Services Group has the instrumentation and training to perform comprehensive evaluations and environmental assessments. All tests are carried out and correlated to applicable industry standards.

Evaluations include: particulate contamination assessments, gaseous contaminant assessments, humidity assessments, product life cycle assessments, room integrity verification, and sealing and HVAC circuit checks.

